

3C Rotary Feeder

Technical Data

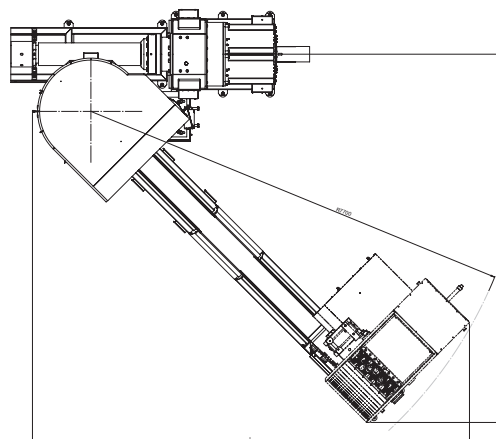
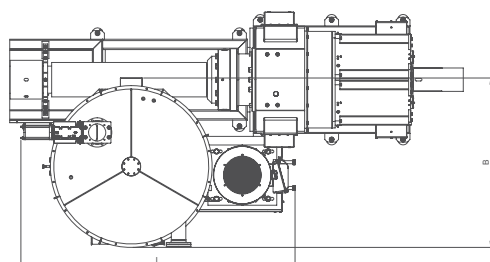
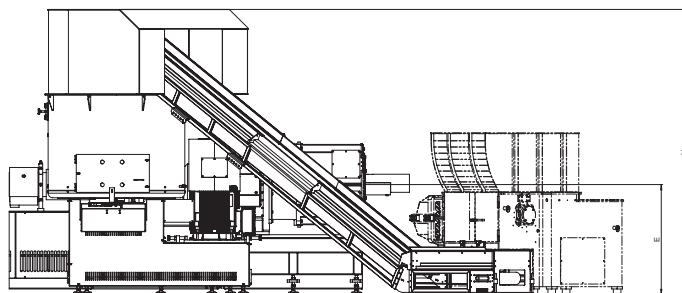
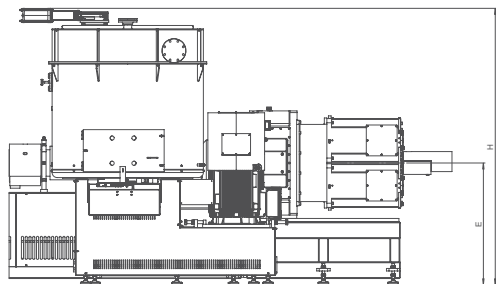

Subject to modifications.

	3C 1000	3C 1100	3C 1300	3C 1400	3C 1500	3C 1800
Size MRS	MRS70	MRS90	MRS110	MRS130	MRS160	MRS200
Screw diameter Ø mm	70	90	110	130	160	200
Drive rating screw kW	110	170	235	355	540	860
Drive rating 3C kW	55	90	132	132	160	200
Extrusion height H mm	1.150	1.150	1.300	1.300	1.450	1.450
with vacuum conveyor						
Length L mm	1.850	2.500	2.800	3.100	3.050	3.500
Width B mm	1.200	1.480	1.680	1.780	1.875	1.970
Height H mm	2.700	2.750	2.900	3.000	3.150	3.250
Weight approx. kg	3.900	4.100	4.400	4.800	5.100	5.600
with conveyor belt and shredder						
Length L mm	7.300	7.350	7.450	7.500	7.550	7.700
Width B mm	6.100	6.150	6.250	6.300	6.350	6.500
Height H mm	3.200	3.250	3.400	3.500	3.650	3.750
Weight approx. kg	5.000	5.200	5.500	6.000	6.500	7.000

* As each machine is engineered to a specific project, the technical data may deviate from the values listed in this table. Detailed information on the relevant technical data is provided to you with your quotation.