

OMNI Recycling System

Technical Data

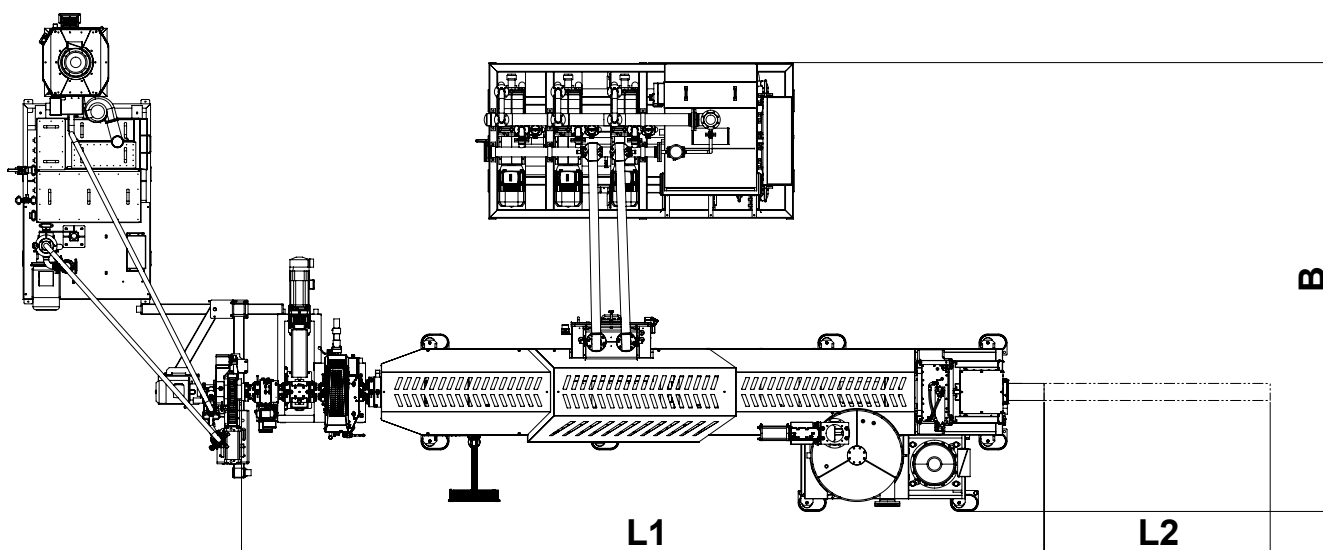
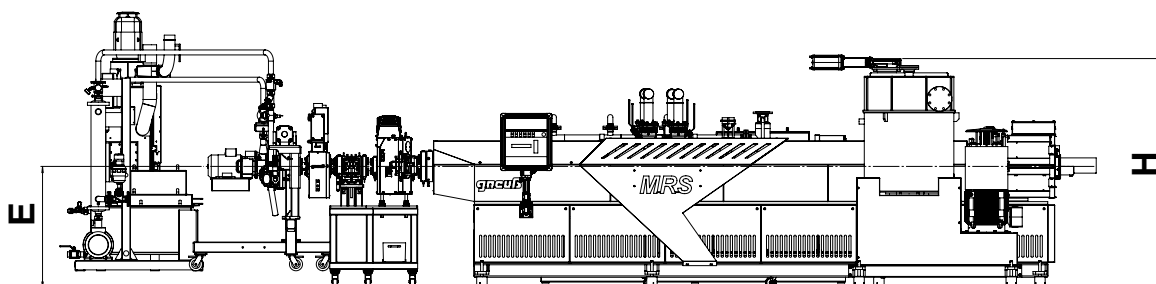

Subject to modifications.

	OMNI 70	OMNI 90	OMNI 110	OMNI 130	OMNI 160	OMNI 200
Throughput PET fiber and BOPET kg/h	250	450	650	1.000	1.400	2.000
Throughput PET bottle flakes kg/h	275	500	700	1.100	1.500	2.200
Throughput PP/PE regrind kg/h	180	320	450	720	980	1.400
Throughput PA fiber kg/h	250	450	650	1.000	1.400	2.000
Throughput PS regrind kg/h	200	350	500	800	1.100	1.600
Height H mm	2.700	2.750	2.900	3.000	3.150	3.250
Extrusion height E	1.150	1.150	1.300	1.300	1.450	1.450
Length L1 mm	6.500	7.500	8.500	9.800	12.700	10.700
Length L2 mm	2.900	3.400	4.000	4.600	6.500	4.600
Width B mm	6.500	6.700	7.000	7.020	7.400	8.100

* As each system is engineered for a specific project, the technical data may deviate from the values listed in this table. Detailed information on the relevant technical data is provided to you with your quotation.