

KSF Series

Technical Data

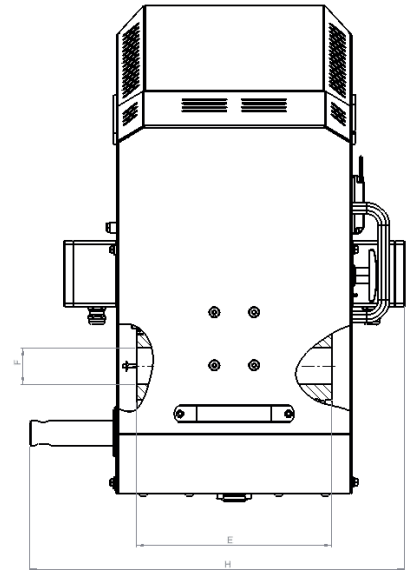
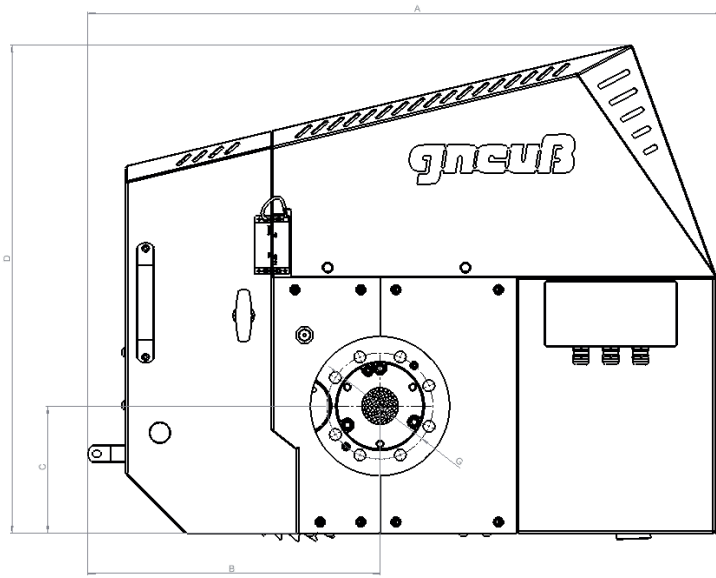

Subject to modifications.

Filter type	active screen area in cm ²	electric heater zones ⁽¹⁾	max. pressure in bar ⁽²⁾	max. temp. in °C ⁽³⁾	Q in kg/h	dimensions in mm								weight in kg
						A	B	C	D	E	F	G	H	
KSF 45	16	2	450	320	75	909	389	157	580	145	20	135	429	118
KSF 60	28	2	450	320	132	887	390	245	725	196	25	135	431	244
KSF 75	45	2	450	320	212	810	398	178	759	230	25	140	501	227
KSF 90	64	2	400	320	301	958	441	192	736	295	25	160	566	370
KSF 110	104	2	400	320	489	1.014	493	244	856	363	30	230	606	570
KSF 130	135	2	350	320	635	1.156	537	289	940	405	35	300	580	950
KSF 150	176	3	350	320	827	1.196	567	329	1.140	445	35	300	539	1.180
KSF 175	240	3	300	320	1128	1.317	553	468	1.288	490	40	220	617	1.725
KSF 200	315	-	300	320	1481	1.713	772	555	1.402	560	45	250	853	2.900
KSF 250	490	-	300	320	2303	1.773	837	585	1.502	660	50	250	909	3.600
KSF 300	705	-	250	320	3314	1.910	970	678	2.040	670	50	250	1054	6.500

(1) = 1 heater zone for liquid heating.

(2) = High pressure versions available as an option.

(3) = Up to 400 °C possible as an option.

(4) = Based on: 1000 Pas, 60 µm und Δp 40 bar.