

KSF Series

Technical Data

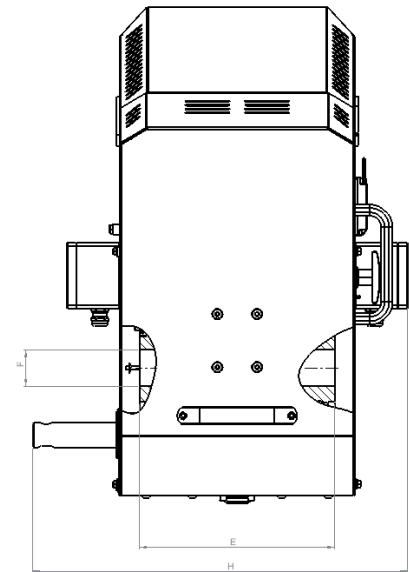
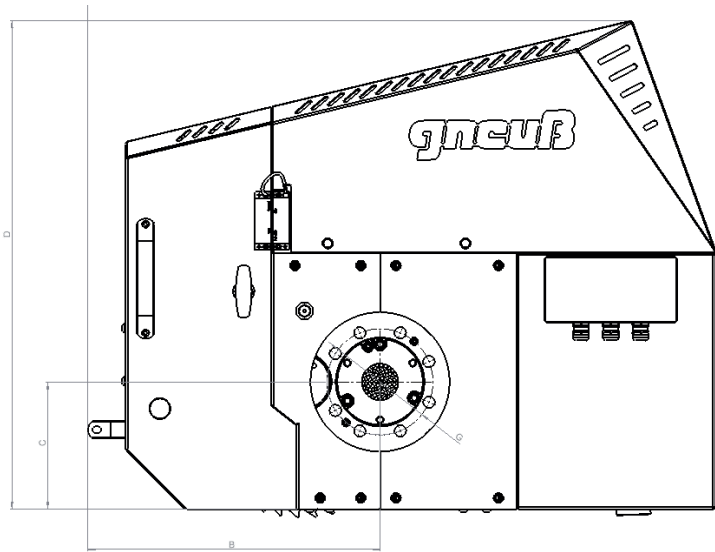

Subject to modifications.

Filter type	active screen area in in ²	electric heater zones (1)	max. pressure in psi ⁽²⁾	max. temp. in °F (3)	Q in lbs/h	dimensions in inch								weight in lbs
						A	B	C	D	E	F	G	H	
KSF 45	2	2	6,527	608	166	36	15	6	23	6	1	5	17	260
KSF 60	4	2	6,527	608	1100	35	15	10	29	8	1	5	17	460
KSF 75	7	2	6,527	608	466	32	16	7	30	9	1	6	20	500
KSF 90	10	2	5,802	608	663	38	17	8	29	12	1	6	22	820
KSF 110	16	2	5,802	608	1,078	40	19	10	34	14	1	9	24	1,260
KSF 130	21	2	5,076	608	1,399	45	21	11	37	16	1	12	23	2,100
KSF 150	27	3	5,076	608	4,600	47	22	13	45	18	1	12	21	2,600
KSF 175	37	3	4,351	608	6,400	52	26	18	51	19	2	9	24	3,800
KSF 200	49	-	4,351	608	8,800	67	30	22	55	22	2	10	34	6,400
KSF 250	76	-	4,351	608	13,200	70	33	23	60	26	2	10	36	7,950
KSF 300	109	-	3,626	608	13,200	75	38	27	80	26	2	10	42	14,330

(1) = 1 heater zone for liquid heating.

(2) = High pressure versions available as an option.

(3) = Up to 750 °F possible as an option.

(4) = Based on: 10,000 poise, 60 microns and Δp 600 psi.