

MDS Extruder

Technical Data

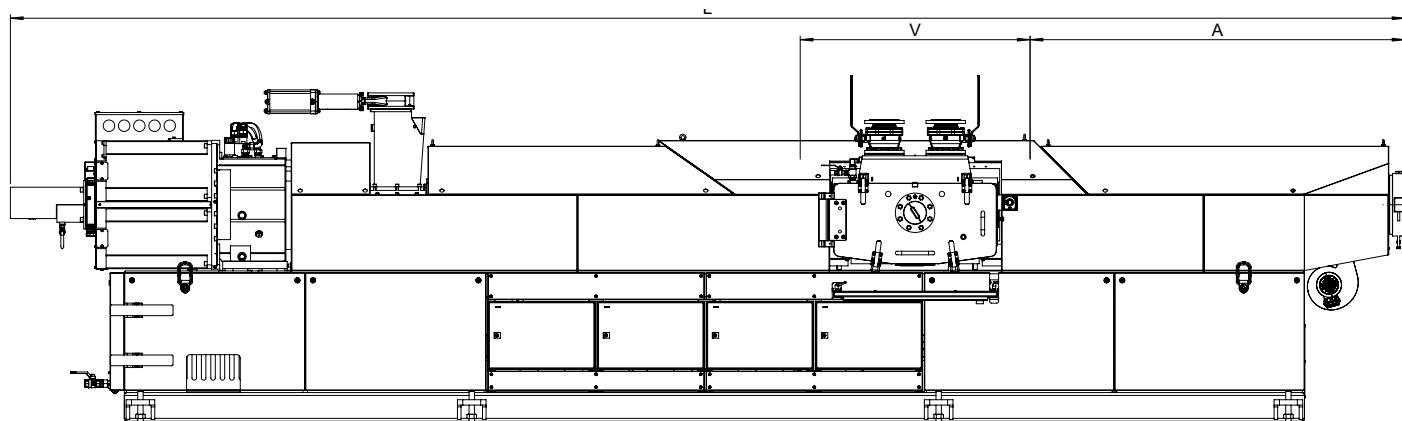

Subject to modifications.

	MDS 35	MDS 50	MDS 70	MDS 90	MDS 110	MDS 130	MDS 160	MDS 200
Screw diameter Ø mm	35	50	70	90	110	130	160	200
Drive rating kW	25	55	107	170	235	355	445	740
Max. screw speed (rpm)	220	210	165	150	120	115	90	75
Extrusion height H mm	700	1,000	1,150	1,150	1,300	1,300	1,450	1,300
Length L mm	2,550	3,100	4,800- 6,100	5,700- 6,900	6,700- 7,950	7,800- 9,500	9,700- 12,150	12,150
Width B mm	480	850	1,200	1,500	1,500	1,200	1,500	1,950
Weight approx. kg	700	1,550	3,250- 4,550	5,450- 7,600	7,100- 10,000	7,700- 10,800	17,500- 21,500	28,000
Throughput rate in kg/h								
PET	35	80	200	450	700	1,000	1,400	2,000
PP + PE	25	60	130	300	450	750	1,000	1,600
PA	28	70	160	360	560	880	1,200	1,900
PS	30	60	150	350	450	750	1,100	1,500

* As each line is engineered to a specific project, the technical data may deviate from the values listed in this table. Detailed information on the relevant technical data is provided to you with your quotation.