

# MDS Extruder

## Technical Data

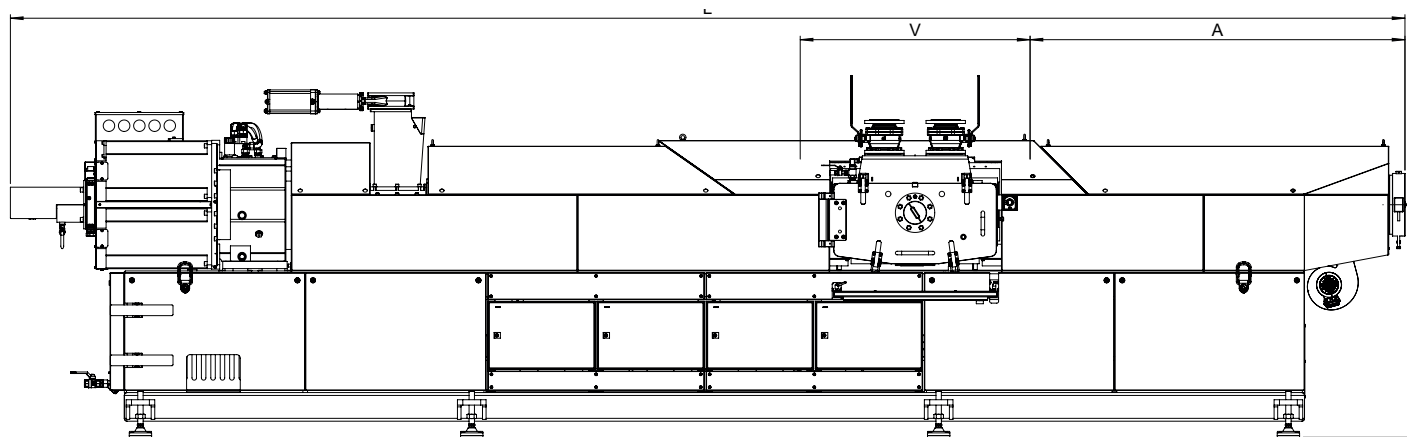

Subject to modifications.

	MDS 35	MDS 50	MDS 70	MDS 90	MDS 110	MDS 130	MDS 160	MDS 200
Screw diameter Ø mm	35	50	70	90	110	130	160	200
Drive rating kW	25	55	107	170	235	355	445	740
Max. screw speed (rpm)	220	210	165	150	120	115	90	75
Extrusion height H in	30	40	45	45	50	50	57	57
Length L in	100	122	190-240	225-270	260-315	310-370	320-480	478
Width B in	20	33	47	58	60	47	58	76
Weight approx. lbs	1,500	3,400	7,200-10,000	12,000-17,000	15,700-22,000	17,000-24,000	38,600-47,400	61,700
<b>Throughput rate in kg/h</b>								
PET	35	80	200	450	700	1,000	1,400	2,000
PP + PE	25	60	130	300	450	750	1,000	1,600
PA	28	70	160	360	560	880	1,200	1,900
PS	30	60	150	350	450	750	1,100	1,500

\* As each line is engineered to a specific project, the technical data may deviate from the values listed in this table. Detailed information on the relevant technical data is provided to you with your quotation.