

MRS Extruder

Technical Data

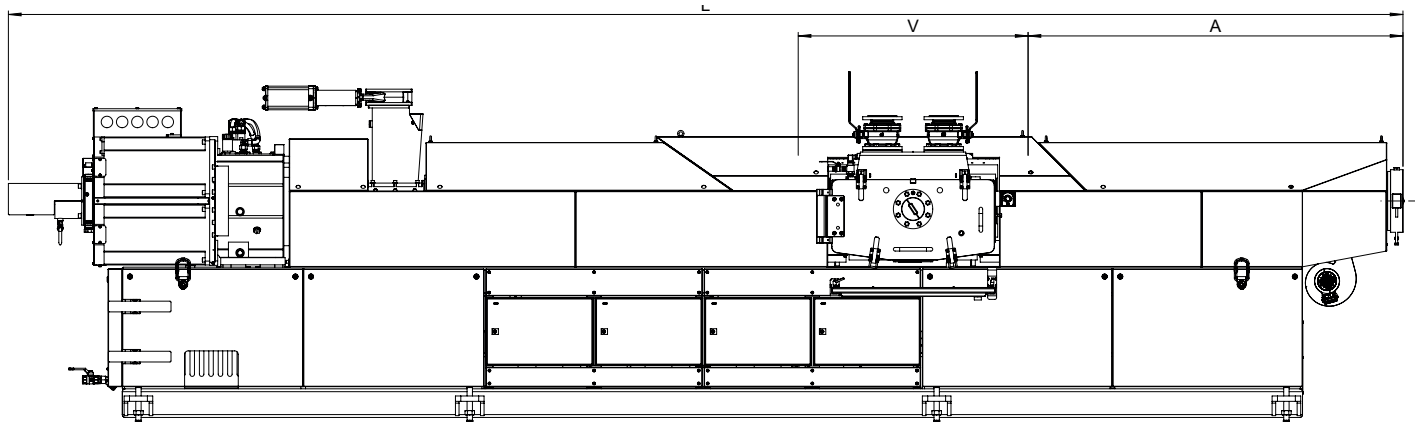

Subject to modifications.

	MRS 35	MRS 50	MRS 70	MRS 90	MRS 110	MRS 130	MRS 160	MRS 200
Screw diameter Ø mm	35	50	70	90	110	130	160	200
Drive rating kW	25	55	107	170	235	355	445	740
max. screw speed (rpm)	220	210	165	150	120	115	90	75
Extrusion height H mm	700	1,000	1,150	1,150	1,300	1,300	1,450	1,300
Length L mm	2,550	3,100	4,800-6,100	5,700-6,900	6,700-7,950	7,800-9,500	9,700-12,150	12,150
Width B mm	480	850	1,200	1,500	1,500	1,200	1,500	1,950
Weight approx. kg	700	1,550	3,250-4,550	5,450-7,600	7,100-10,000	7,700-10,800	17,500-21,500	28,000
Throughput rate in kg/h								
PET	35	80	200	450	700	1,000	1,400	2,000
PP	25	60	130	300	450	750	1,000	1,600
PA	28	70	160	360	560	880	1,200	1,900
PS	30	60	150	350	450	750	1,100	1,500

* As each line is engineered to a specific project, the technical data may deviate from the values listed in this table. Detailed information on the relevant technical data is provided to you with your quotation.